

# STI Mini Theft Stopper®



STI-6255

## PRODUCT OVERVIEW

The Mini Theft Stopper is an inexpensive yet highly effective way to protect fire extinguishers and a wide range of other firefighting equipment from theft and misuse. The device is compact, highly effective and extremely versatile. It does not interfere with firefighting in any way and its simplicity of design contributes to its high degree of reliability.

## HOW IT WORKS

### For free-standing extinguishers or equipment

The Mini Theft Stopper comes with a special clip that can be used in several ways. An extinguisher's pull pin may be routed through the holes in both prongs of the clip. The clip is then held in place by the extinguisher's seal and when the seal is broken to use the extinguisher, the alarm sounds. The steel clip can also be placed under any type of equipment. When lifted, the alarm sounds immediately.

### For cabinets housing fire extinguisher, fire hoses or sprinkler shut off valves

The Mini Theft Stopper is mounted next to the door or in the cabinet and its reed switch unit is mounted in the door jam. The matching magnet is mounted on the door in close proximity. When the door is opened the device emits a 95 dB (a 1 metre) warning alarm.

## KEY FEATURES

### General Information

- Protects free-standing and cabinet housed fire extinguishers and other equipment.
- Three year guarantee against breakage of polycarbonate housing (one year on electromechanical and electronic components).

### Design

- Helvetica Neue
- Compact design (84mm diameter x 25mm deep) mounts easily next to the extinguisher.

### Construction

Tough, ABS construction.

### Installation

- Highly versatile; can be door mounted or fitted directly to the fire extinguisher pull pin.
- Does not interfere with use of protected firefighting equipment.
- Easy to install.

### Electronics

- Self-contained 9 VDC alkaline power source is provided.
- Sounds a powerful 95 dB (at 1 metre) warning alarm when activated.

### Options

- Three minute automatic reset upon activation.
- A magnetic reed switch activation for cabinets and display cases and unique steel contact clip activation for fire extinguisher pins and other free-standing equipment.
- Service pin provided for authorised personnel.
- Extremely cost effective and easy to install.

# STI Mini Theft Stopper®

Dimensions and Technical Information

## MODELS AVAILABLE

- STI-6255** Mini Theft Stopper
- STI-6255/M2** Double Point Mini Theft Stopper  
(protects 2 extinguishers using 2 spring clips)

### Accessories:

- E009** Service Pin
- KIT-131** Steel Contact Clip Switch
- KIT-132** Magnetic Reed Switch

## SPECIFICATIONS

<b>Housing</b>	3mm ABS
<b>Dimensions</b>	84mm H x 84mm W x 25mm D
<b>Sounder Output (at 1 metre)</b>	95 dB
<b>Operation</b>	Steel Contact Clip Switch Magnetic Reed Switch
<b>Standby Current</b>	None
<b>Alarm Current</b>	115 mA
<b>Auto Reset</b>	3 minutes

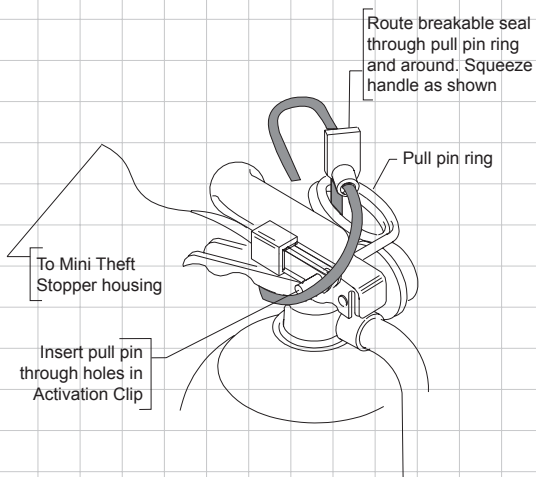
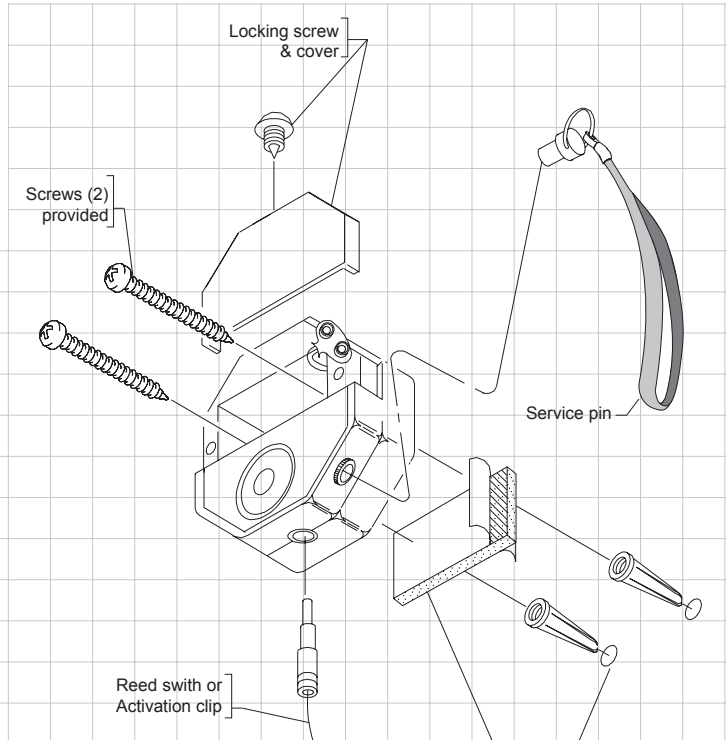
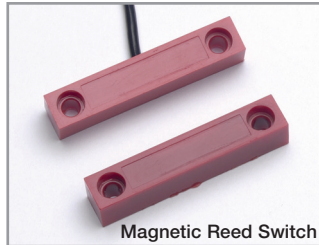

Steel Contact Clip Switch Activation

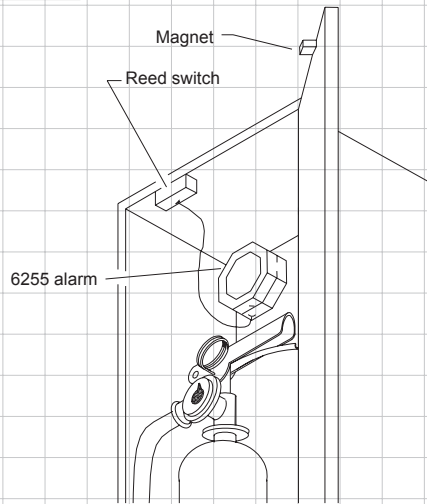

Magnetic Reed Switch Activation



**Safety Technology International**

Taylor House  
34 Sherwood Road  
Bromsgrove  
Worcestershire  
B60 3DR, England

Tel: +44 (0)1527 520 999  
Fax: +44 (0)1527 501 999  
info@sti-emea.com  
www.sti-emea.com

2306 Airport Road  
Waterford, Michigan  
48327, USA

Tel: 248-673-9898  
Fax: 248-673-1246  
Toll-free: 0800-888-4784  
info@sti-usa.com  
www.sti-usa.com